

# Vibroswitch Model-1500EX

Detects unusually vibrations and outputs an alarm signal.  
Can be used in a hazardous area where explosive gasses are exist.



- Vibration modes: acceleration, velocity and displacement can be select with internal switch.
- Flameproof construction: EX d IIB T6.
- The sensor is combined with the amplifier via a flexible wire conduit.
- Alarm level can be set between 1% to 99% of full scale with internal rotary switch.
- Alarm delay can be set between 0 to 60 seconds to prevent an incorrect action.
- Usable for monitoring vibrations of motors, fans, pumps, and so on.

# For Explosive Atmospheres *Vibroswitch* **Model-1500EX**

## SPECIFICATIONS

Alarm setting range: ①Acceleration 1~99m/s<sup>2</sup>(Peak)  
 (Select 1, 2 or 3) ②Velocity 1~99mm/s (Peak)  
 ③Displacement 0.01~0.99mm (P-P)

Frequency range: 10~500

Accuracy: Within 5% (at 25°C, 80Hz, 10m/s<sup>2</sup> measurement of sinusoidal wave)

Linearity: Within 1% of full scale

Driving power supply: AC or DC 100~220V (less than 10VA)

Relay operation: Delay 0 to 60 sec variable  
 Self-holding operation and automatic resetting operation, make contact by solid state relay.  
 (Resetting by turning off driving power supply)  
 Contact rating AC/DC 125V, 0.5A

Housing construction: Flameproof construction  
 Ex d IIBT6 (Certificate No. C12041)

Vibration resistance: Sensor: 10G for vibration, 100G for shock  
 Amplifier: 2G for vibration, 30G for shock

Dielectric strength: 1500V AC between relay contact and housing for 1 minute  
 1500V AC between relay contact and power supply for 1 minute

## DIMENSIONS

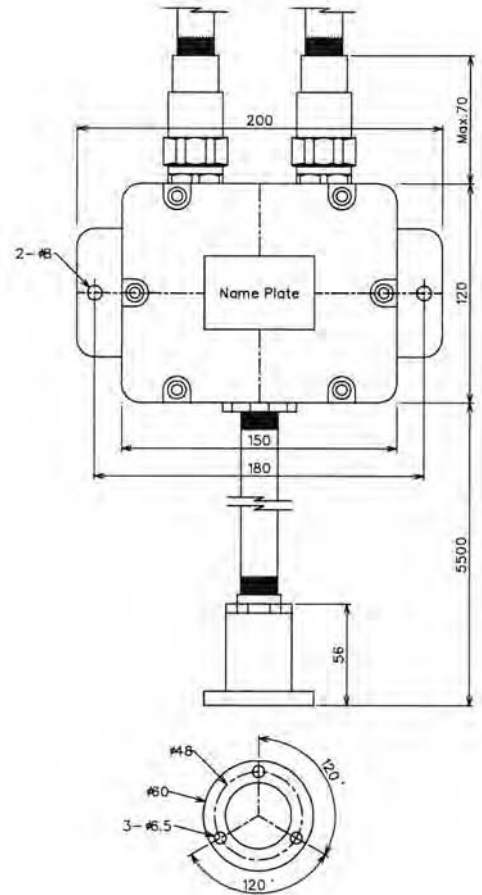

UNIT : mm

## BLOCK DIAGRAM AND CONNECTION

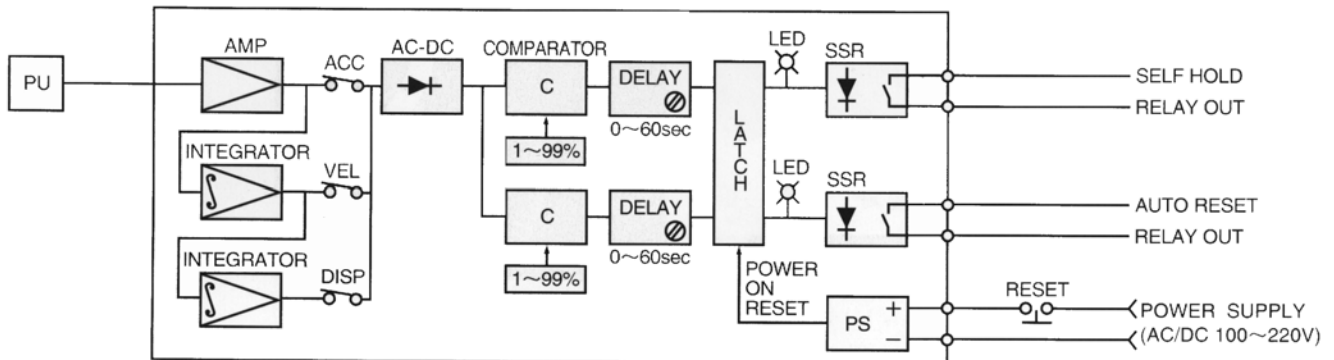

**SHOWA** Always satisfying needs for Safety and Comfortability.

### SHOWA SOKKI CORPORATION

■Head Office:  
 1-5-9, Kandaizumi-cho, Chiyodaku, Tokyo, 101-0024 JAPAN.  
 Phone : 03-3866-3210 Fax : 03-3866-3060

■Factory:  
 1547-1 Takao-machi, Hachioji-shi, Tokyo, 193-0832 JAPAN.  
 Phone : 042-664-3232 Fax : 042-664-3276  
<http://www.showasokki.co.jp/>  
 e-mail: eigyo@showasokki.co.jp

### AGENT:



312, Sai Chambers, Near Santacruz Bus Depot,  
 Santacruz (East), Mumbai - 400 055  
 Telephone: +91-22-6697 6816/ 67  
 Fax: +91-22-2610 9608  
 Email: sales@suntek-services.com  
 Website: <http://www.suntek-services.com>