



DIGITAL VIBRATION MONITOR
4-20mA Input/Digital Vibration Monitor

MODEL

2590B



In combination with any of the vibration converters, Vibro Converter 2502 Series, this digital allows you to measure and monitor vibrations easily.

On receiving a 4-20mA signal from a vibration converter, this unit scales it into a vibration value and displays it digitally. This digital vibration monitor also allows you to monitor vibrations with alarm contact outputs in up to two stages. With a built-in operating power supply for vibration converter, this unit is easy to install. It can combine with various vibration converters.

DIGITAL VIBRATION MONITOR

4-20mA Input/Digital Vibration Monitor

MODEL 2590B

Features

- On receiving 4-20mA signals, this unit scales them into vibration values. The vibration values are digitally displayed on red LEDs.
- It has a built-in power supply for Vibro Converter.
- It has a built-in alarm relay in up to two stages.
- The alarm relay has a built-in delay timer to prevent malfunctions.
- It allows a vibration monitoring system to be built up at low cost.
- Insulated analog outputs 4-20mA, 0-5V, and 1-5V can be taken out onto independent terminals (optional).

Specifications

Input signal	4 to 20mA (with a zero and span fine-adjustor)
Input resistance	10Ω
Display range*	Configurable from 0 to a desirable full-scale value
Display	7-segment red LED, 5 digits
Display cycle*	Configurable to 0.125, 0.25, 0.5, 1, 2, 3, 4, and 5 seconds; 1 second is the standard
Accuracy	±0.3 ±1 digit (23°C ± 5°C)
Driving power supply for converter	+24V DC, 100mA max.
Alarm settings*	Configurable to any value, up to 2 stages: AL1 and AL2. Automatic reset and self-holding capability
Alarm value checkup	Press the AL1 or AL2 key to display the setting.
Alarm relay	1C contact each. Ratings: 250V AC, 5A; 30V DC, 5A maximum (resistance load)
Alarm delay*	Configurable to a desired value between 0.1 and 99.9 seconds; 5 seconds as the standard
Analog output (OP)	An optional model with insulated analog outputs is available. Output types: 4-20mA (500Ωmax), 0 to 5V, 1 to 5V, 0 to 10V (5kΩ min)
Power supply	85 to 264V AC 50/60Hz, 15VA max. [An optional power supply 24V DC (10W maximum) is available.]
Operating temperature and humidity	0 to 50°C 45 to 85%RH (non-condensing)
Front panel	IP65(need rubber packing)
Weight	Approx. 300g

The items marked * are factory-configured to the appropriate values.

Outside dimensions

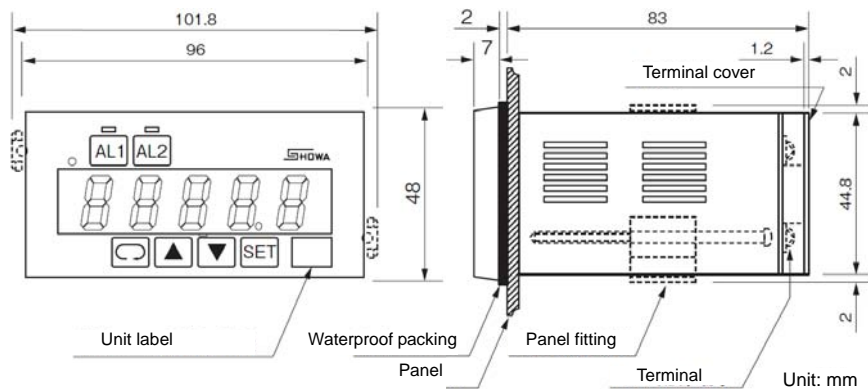

The specifications and designs described in this catalog are subject to change without notice for product enhancement.

SHOWA Respond to the needs; "safe and comfortable"

SHOWA SOKKI CORPORATION

■ Head Office:
1-5-9, Kandaizumi-cho, Chiyoda-ku, Tokyo, 101-0024 JAPAN.
Phone: 03-3866-3210 Fax: 03-3866-3060

■ Factory
1-8 Sanda-cho 5-chome, Hachioji, Tokyo, 193-0832 JAPAN.
Phone: 0426-64-3232 Fax: 0426-64-3276
<http://www.showasokki.co.jp/> E-mail: eigyo@showasokki.co.jp

Typical connections to a Vibro Converter

● Connection to a 2503

When a cable having the same capacity (0.3mm²) as the cable furnished with a 2503 is used, it can be extended to about 10km.

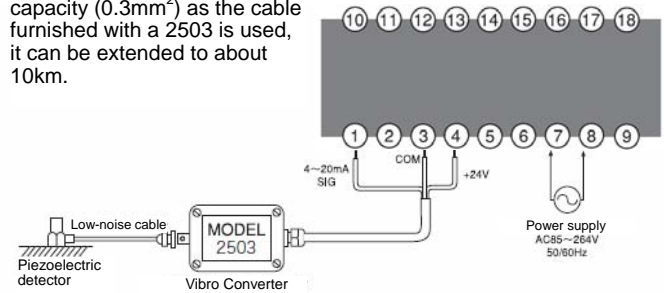

Terminal arrangement for Model 2590B (in the back)

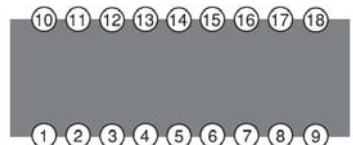

● Connection to a 2502

Wire ratings: 0.2-1.3mm² (AWG 24-16)
A 1.3mm² cable can extend to about 50km.
A 0.2mm² cable can extend to about 8km.

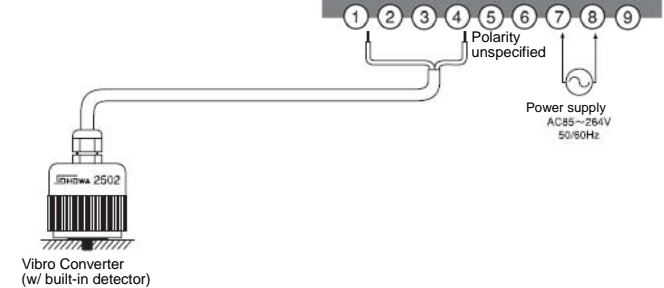

Terminal arrangement for Model 2590B (in the back)

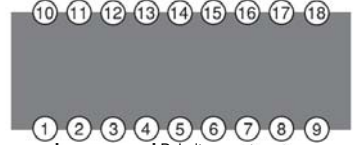

● Panel cut dimensions

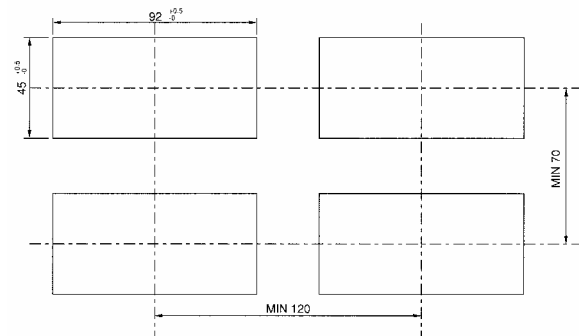

Terminal arrangement for Model 2590B (in the back)

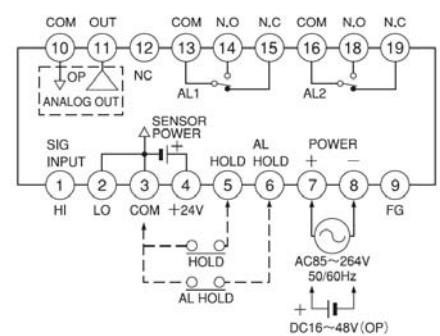

Agent:



312, Sai Chambers, Near Santacruz Bus Depot,
Santacruz (East), Mumbai - 400 055
Telephone: +91-22-6697 6816/ 67
Fax: +91-22-2610 9608
Email: sales@suntek-services.com
Website: <http://www.suntek-services.com>